

CAM



VOLUME 2 NUMBER 8

JUNE 1945

PUBLISHED BY THE DIRECTORATE OF MECHANICAL ENGINEERING, N.D.H.Q., OTTAWA, CANADA

LEADING LADY IN THE ARMY SHOW

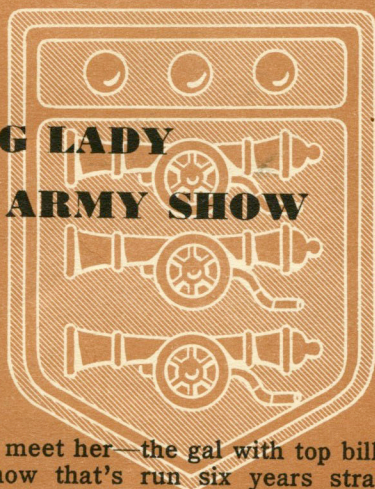

STEP up and meet her—the gal with top billing in a whopping big show that's run six years straight—and still going.

We got to talking about this thing the other day and it always added up to the same answer. The Gun. The Leading Lady that brought the Axis house down in Africa, Italy and all across Europe and will roll them from the Isles of the Pacific.

Because of this, your job, directly or indirectly, is to transport, feed and care for guns. That's what makes you just as important as the man who pulls the lanyard or squeezes the trigger.

Mebbe you overhaul carburetors or fix flats. This is the maintenance that moves the trucks that haul the food that feed the men that load the ammo for the guns that blast the pill box the Jap built.

Shift it anyway you want—you are a cog that meshes with cogs that finally work the gun.

That's what makes maintenance so damned important all down the line, from the hulking self-propelled mount to the peewee Chorehorse. What's good for a Howitzer is good for a 6 x 4 truck—and rust, dust and loose joints in a jeep's carb or a 4.2 mortar will slap you down equally fast when you're nudging elbows with the Nips.

Yet, in the heads of the gunners who man the guns is an ingrained penchant for spic and polish. They're fanatics on check and double check—worry warts on preventive maintenance. Maybe because they live with these explosive prima donnas they're more sensitive about the results of mechanical failures. Their noggins are full of bad dreams about misfires, prematures, breeches not closing—all in the face of banzai charges.

Don't get us wrong. We're not saying that every gun we've ever seen has been slick, stripped and ready for action—nor are all our vehicles and other equipments scraping around with their differentials dragging. We've seen guns we wouldn't stand within a thousand yards of if they were loaded. But we didn't see them often. Not as often as we've seen a regiment with bright shiny armament moving on grease starved rust flecked transport.

In the theatre of war the Leading Lady does her stuff with inspired efficiency—maintained that way by an equally maintenance conscious supporting cast.

Up front, it has to be that way.



JUNE - 1945

Vol. 2 No. 8



CONTENTS

	Page
Examination of Guns.....	141
Harley Support Stand.....	143
Circuit Breakers.....	144
Lubricating Tracks.....	145
Foresee the Future.....	146
Telephone Switch Plunger....	146
Dash Board (For B.Fs.).....	147
Radiator Repair.....	148
Ignition Switch.....	150
Motorcycle Battery Posts	150
Forms for Small Arms.....	151
Tire Locking Rings.....	152
Benny Boob.....	153
Sgt. O'Sweat.....	154
Valve Springs	
Jeep Speedometer Trouble	
Battery Polarity	
Propeller Shaft Brake Drums	
Speedometers.....	156
G.M. Brake Cylinders.....	157
Shipping Gun Parts.....	158
Fire Extinguishers.....	159
Special Tools.....	Inside Back Cover



CAM is published monthly in the interests of Mechanical Maintenance, and directed to the non-commissioned officers and men of the Canadian Army.

Your contributions of articles and ideas are welcome. Address all correspondence to the Editor, CAM, Directorate of Mechanical Engineering, Department of National Defence, Ottawa.

EXAMINATION OF GUNS

ONCE upon a time there was a guy who had nice shiny pips and figured that he knew all about inspections and examinations. You know, the real kind with A.F.G.'s 875 and Memos. of Exam and such. Being a R.C.E.M.E. type, naturally we don't mean the kind where the little man in big pants comes and scares the livin' daylight-saving out of you. Well, it's a long story but our friend has seen a lot of shootin' irons, big and little, and now he's not so sure about knowing all that there is to know about inspections.

First, there's a wide world of difference betwixt an inspection and an examination: An examination means giving a gun that has been in service a really fishy stare and finding out all its little private skeletons. Don't blame us, it's the C.A.L.E.M.E.I. (Armament A 520 [CA.], Instn. No. 1, Issue 1) what sez a full examination consists of (a) Visual examination; (b) Taking impressions; (c) Measuring; (d) Gauging, testing, etc. Inspection, on the other hand, is like the sailor looking over the homely girl with nice legs; he looks twice but goes no further. But if he's a bright intelligent sailor he learns a lot in those two looks! So, if you're a gunner type don't get discouraged, you can find out all you want to know about your tubes if you look twice, think twice and know what to look for.

Any Number One who has attended a good accident checks his bore automatically between rounds. He knows that a stripped land, or a cracked tube, may lead to a premature and when that gun of his splits open and looks like a lily, it will be the only bouquet the

army will ever give him. It's also hard on the guys who are standing around. But most gunners will look a long time before seeing either of these unhappy things, provided they keep looking. Stop once or twice and maybe your number is up and then you're caught W.Y.P.D.*. Just as important to watch, and for the same reason, are flattened lands. A flattened land (not a prairie, you dope) means a narrowed groove and when that shell starts up the bore, and the driving band hits the deformed groove, the brakes are slapped on hard. Maybe she'll go bang, maybe it will drop the band off the shell and you'll have a wild round (Oops, sorry pardner! I didn't mean to knock your out-house down), or maybe you'll rip out a land. Then, if you aren't looking, the next round will result in two bangs. The same thing goes for a steel choke; you may not be able to see this but if you know there is one you can usually see a bright ring around the bore. If you don't know there is one you probably won't see it at all. So, go to old Grandpappy (the E.M.E., he knows all) and get him to pass the "gauge plug bore low limit for provisional condemnation" through before practice (it's only a hunk of iron).

Then again, maybe that corner you took a bit too fast a week ago last Thursday, and rolled her over, has put a bit of a kink in her. (*Note to Gun Sergeants: It has happened.*) Well, brother, it's your head not mine, I joined up to fight but not necessarily to die for my country. If you feel the same way, Grandpappy will help you out again. And just because the paint hasn't

When you know what the eagle-eyed Boogieman looks for—you're a jump of maint'nce ahead of any blow up.



*Improperly dressed.

been scratched don't think she hasn't been bent. (If an E.M.E. is reading this, check for droop or sweep both in horizontal and vertical planes after a road accident.)

O.K.! So you ain't daid yet and you know the bore is alright. Ever hear of a "hang-fire"? Well, they are lots of fun and a good way to get them is improper striker protrusion, or dirty firing mechanisms.

Now this paragraph really hasn't any business being here but, as there's no gunner like a healthy gunner, for the love of Sergeants don't forget to make the serviceability tests on your recoil system. One of these days someone is going to get a face fulla gun if this isn't checked. When she fires there is a lot of metal going places in a hurry and if the recoil system doesn't stop it, it's a cinch you will. Check your platform stays like an anxious Mother for the same reason. And in case you ever have to get a gun the hell out of somewhere in a hurry it's comforting to have acquired the habit of correct maintenance on the running gear. It's too late when the time comes.

Now! Maybe you've got a hankerin' to know why Grandpappy does those funny things with gauges. Well, take your shoes off, son and have a chew. Grandpappy may be crazy (I.Y.O.D.F.)*, but there's a good reason for all he does at an examination. If he's very old and very wise, even as you and I, he will probably proceed in the following sequence. Now, it's not that he doesn't trust gunners but just to start he will make a quick visual check to make sure all is nice and clean, and besides, it helps to know what sort of a gun he is looking at. Then he will try and pass the gauge plug bore. If the G.P.B. slides through nice and easily he knows that, apart from the driving band, the projectile will do the same.

Now Grandpappy, at this point,

since he can't summon up a "Genril," will probably spend half a day trying to get some gunners to give him a hand. It's a nice harmless game but it's a bit tough on Grandpappy, so give in and help before he's all worn out. He will want the gunners to remove the muzzle brake, and loose barrel, if applicable. Now he will check



the brake for burrs, coppering and choke, and check the exterior of the loose barrel, or liner, for condition. What he says will depend on what you have or have not done. If he finds any pitting or rust his vocabulary may surprise you. But tilt your haloes back and assume all is nice and shiny and the silly man is peering down the bore at a brass can with a lamp and a mirror in it. If he's really posh maybe he'll be using binoculars. Grandpappy is now really doing more thoroughly what you do between rounds and during pauses. If there is any cracking or flattening of the lands, or maybe scoring or pitting, the old boy will find it.

Next there will be a flourish and much time consumed measuring bore diameters. Generally speaking wear is worse at the commencement of rifling, it's hard to measure accurately here so normally the wear at a point one inch ahead of the commencement of

rifling is taken as an index of wear through the tube. Of course if Grandpappy is worried about spiral abrasion, or damage from bumps on the outside, he'll cuss a bit and take measurements throughout the bore. Same thing if the G.P.B. sticks or he ain't got one.

Now, if Grandpappy has found any sign of trouble on his visual check he should have gone over to the cook, wolfed a piece of pie, and asked him to get lots of hot water ready. Probably he didn't, so now he goes to the cook, wolfs a piece of pie, and asks him to get lots of hot water ready. (If he had gone in the first place he might have had two pieces.) Having the hot water eventually, he will knead up some gutta percha and press a nice slab of it against any defect he has found; this when cool gives him an impression of the damage and serves two purposes. First, it enables him to measure the depth of scoring and extent of damage, and hence assess whether or not safety is affected, and, second: it allows the brass bound bottoms among the chair borne troops (or more politely referred to as the "Great Grandpappys") to see what happened.

Next, a careful examination of the jacket and breach ring will be made to ensure that no cracks are starting and that they are free from rust and dirt. Grandpappy will be very careful that there will be no dirt between the liner and the jacket. Of course, you will too, but it makes the old boy feel better if he can find something just a little bit wrong. Then you'll all cuss a bit and re-assemble liner jacket and ring, and connect up the recoil system.

What Grandpappy does next depends on what type of gun he's checking, but generally speaking he will go over the breech and firing mechanism, checking for burrs and signs of wear. He will

*It's your own damn fault.

ensure, in the words of the good book, that "all is serviceable." Then he will re-assemble, check striker protrusion and Cartridge Head Clearance if Q.F. Right here is where a lot of trouble starts. If the protrusion is not right the force of blow will be wrong, if it's very bad, failure of obturation may result and that's messy, very messy. Now, if force of blow is wrong the primer may act like a damp squib and we get a mis-fire or hang-fire. So, having made sure everything else is O.K. "Old Fungusface" will measure the force of blow of the striker. If he's wise he'll take it at least three times because if it's near the low limit it's apt to be a deceptive brute. If he is very wise, he will take the average of five readings after he has had the gunners lubricate the mechanism in their usual fashion and, if the weather is cold, he will make sure

it's cooled down to outside temperature.

Finally he will cheer up a bit, scream for some more gunners and do a pull-back test to check semi-automatic functioning; of course he should have checked the semi-auto cam first but he's sure to have forgotten that. Then, if you're not timid, remind him to check fit of extractors. Bud! He will really love you. Besides, it will get him in a good state of mind to check life history documents.

Now, these here life history documents have caused more grief and grumbling than most anything else. Believe it or not, they are important. You see, somewhere there is a group known as the "Back-room Boys." They are the "Joes" what design the guns. Since the proof of the pudding is in the eating, and they are much too busy to shoot out all the guns

they make, the only way they can know if a gun is worth while or not mechanically, is by its record. Also the life history record ensures that progressive faults are watched and caught in time. If you fired one series and found half an inch of scoring you would rightfully have a hemorrhage, but if it was the result of many thousands of rounds you would not worry. Then again, history records save a lot of "buck-passing." At a given date either a gun was serviceable or 'twern't. Now, keeping life history records is a cinch if you never put off till tomorrow what you should record today. You can tip yourself off and brush yourself up on the procedure by looking through C.A.L.E.M.E.I.'s Armament A161 Instruction Nos. 1 and 2. And first thing you know, you'll be the fair haired boy in any man's gun pit.

X Y Z

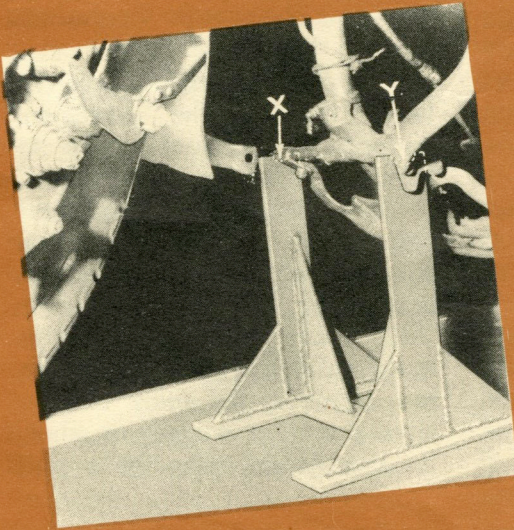

Harley Support Stand

EVER have a bike fall on you when you were working on its front end? If you haven't it's a pretty sure bet you've had some close calls. This solid little number solves the problem on the Harley-Davidson WLC model according to the motorcycle boys in No. 3 Coy R.C.E.M.E. Workshop, Kingston. It's not much of a trick to make and it will hold the bike like it was nailed to the floor.

Just in case you too would like to give Junior back his blocks and make a front end holder upper for yourself we've made a few sketches showing the particulars. Maybe you'd better look twice at the two points where the bike is actually supported because the two half-round notches at 'X' and 'Y' in the picture are not the same size. One is 1 1/4" while the other is 3/4".

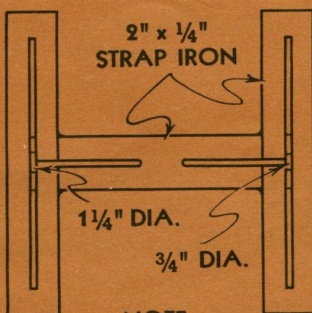

NOTE:
ALL PARTS
ELECTRIC WELDED

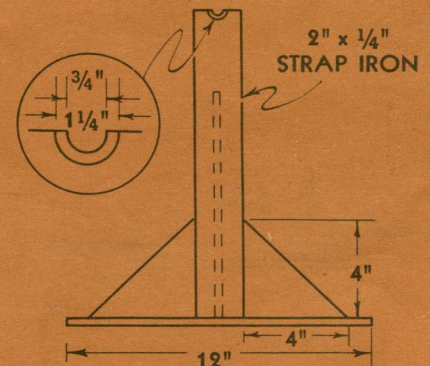
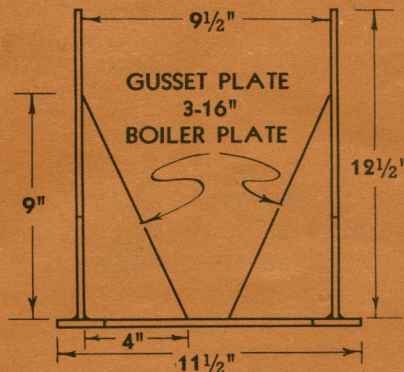

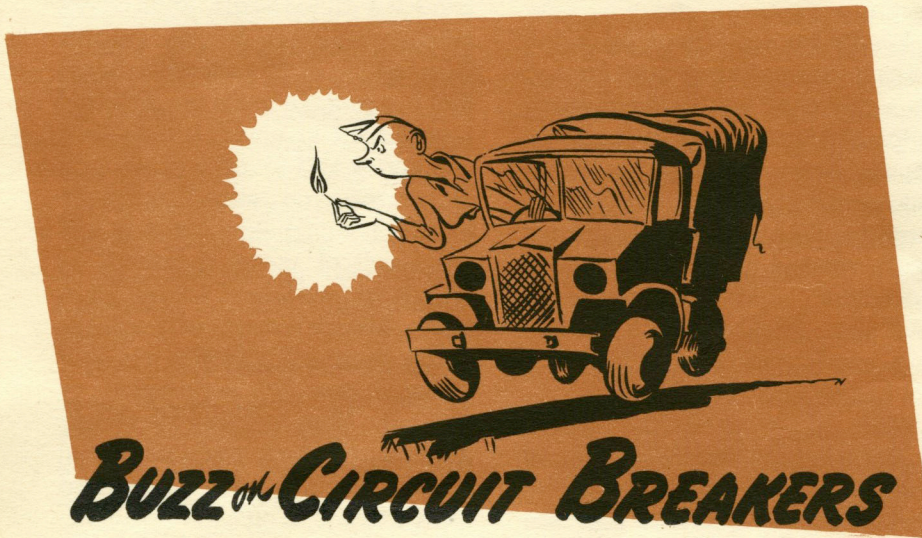

On systems equipped with a circuit breaker the lights will also go out—but due to the design of the circuit breaker—they won't always stay out.

There are several different types of circuit breakers. Some are relays and look something like the generator cut-out relay—other types are merely a set of contacts on a bimetal strip. To illustrate, we've made three different pictures of circuit breakers.

Fig. 1 shows an ordinary relay. If you understand how this one operates you'll understand how most relays operate — including voltage and current regulators.

Current enters at terminal 'A' and passes through the heavy winding which is wound around the iron core. When current flows through a wire wound around an iron core a magnetic pull is set up. The strength of this magnetic pull depends on how much current is flowing through the winding. The greater the current flow the stronger the pull.

From the winding the current flows through the armature, through the contact points to terminal 'B' which is connected to the lights. All the current going to the lights, then, must first pass through the relay coil and points.

If the current going to the lights is normal there won't be enough magnetism in the relay core to effect the relay one way or other. If a short occurs in the light circuit

... some do, some don't
but whether they buzz or
not there's no need to get
panicky.

You see, these circuit breakers take the place of fuses on most vehicles. They're an overload switch that opens up the circuit if a ground or short occurs in the electrical system.

If a lighting circuit is protected by a fuse and the fuse blows on account of too much current in the circuit—the lights go out. They'll stay out too—until a new fuse is installed* or (and this isn't good) a piece of tin foil or a chunk of metal is placed between the fuse clips.

*You corrected the trouble of course.

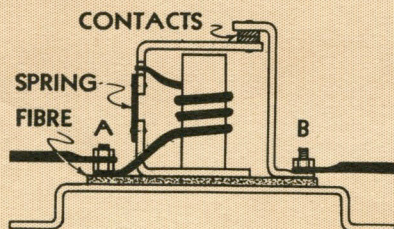

Fig. 1—The buzzer type circuit breaker.

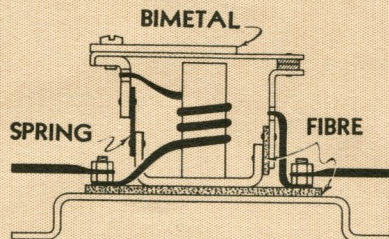

Fig. 2—The combination kind it opens and closes slowly.

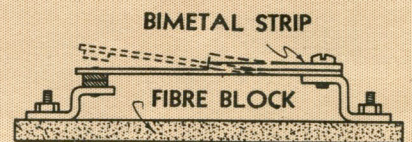

Fig. 3—The ungarnished job . . . it also operates in slow motion.

things will begin to happen. The extra current caused by the short or ground will increase the magnetic strength of the magnet and will pull the armature towards the core. This causes the contact points to be pulled apart—which of course breaks the circuit.

As soon as the circuit is broken no current will flow through the winding—so there isn't any magnetism left to keep the points open—and they close again. Then the magnetism builds up and reopens them. Thus, the points will keep on opening and closing rapidly whenever too much current is flowing into the circuit. And that's why this type of circuit breaker buzzes.

The only way to stop it buzzing is disconnect the circuit that is shorted or locate and remove the short or ground that is causing the excessive current flow. That's why it's so handy in locating trouble. All you've got to do is turn off the lights, one circuit at a time. For example—if the circuit breaker only buzzes when the parking lights are on, the trouble must be in the parking light circuit. So you leave the parking lights on and go hunting for the trouble. When you find it and correct it the buzzing will stop. Feeling the various wires while the buzzer buzzes may help you to track down the short because the wire with the short in it will usually be warm.

Some smart trouble shooters use this vibrating type of circuit breaker when they haven't got a voltmeter, to locate wiring grief.

The circuit breaker shown in Fig. 2 is the type used on Fords. This one doesn't vibrate or buzz. Instead it opens and closes slowly when too much current passes through it. (That's what caused McWortle's lights to go out every half mile). The armature on this relay is a bimetal strip. When too much current flows through the circuit the bimetal strip heats and

bends upward causing the points to separate. The circuit is then broken and won't close again until the bimetal strip cools off. The relay in this type of circuit breaker is only used to make better contact of the points while the circuit is closed.

Then there's the third type (Fig. 3). This circuit breaker is the same as the Ford type except it has no relay and depends entirely upon the expansion and contraction of the bimetal strip. When excessive current flows through the bimetal strip and contacts, the bimetal strip expands

and bends upward, separating the contacts.

The adjustments on all types of circuit breakers are set at the factory and sealed. They should never be fiddled with because changing them destroys their main purpose in life — and that is to protect the electrical system against current overload.

However, an understanding of how and why they operate won't do anyone any harm and may save you blowing your top if one starts buzzing in your ear or if the lights on your vehicle start blinking like a light house.

X Y Z

Tracks of Oil

TANK and Carrier tracks should never be lubricated—even in the best of circles. Which fact, says you, weesis well acquainted with. We too thought it was common knowledge among men who ride on tracks instead of wheels. That's why you could have sent us sprawling with a cotter pin when we heard that a few well meaning nut busters were conscientiously coating track links with penetrating oil or other petroleum products.

A mixture of oil and grit makes a fine abrasive for grinding valves and track pins—but who wants to grind track pins? In case there is any argument, the story goes like this. Track pins and links are made of special alloys which, after a short period of operating dry, obtain a highly polished wear resisting surface.

Tank tracks seldom if ever become rusted solid but Universal Carrier tracks present a different story. When carrier tracks (either off or on vehicles) lie around in the open for awhile, nature takes its corrosive course. Certain parts will become good and rusty. If left long enough the pins will

freeze solid and must be freed up before they are put into use. When this happens, instead of reaching for an oil can, unlimber your knotty old biceps and tap each pin and link with a hammer to knock off the exterior coating of rust.

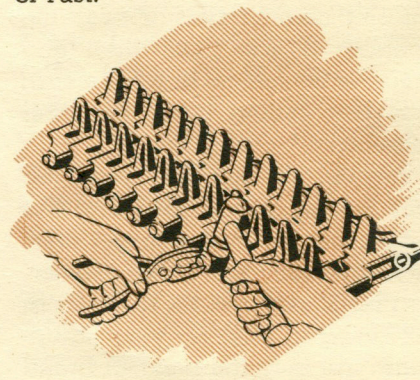

Next, grasp the washer at the welded end of each track pin with a pair of pliers, at the same time tap the pin and adjoining links with the hammer until the pin will rotate freely. Each pin must be checked and freed if necessary before the vehicle starts to roll and the whole job must be done dry.

Lubricating tracks is just like putting glue on them—all the oil or grease will do is pick up grit, sand and trouble.

X Y Z

Foresee the Future



**So that you'll have parts—
not time on your hands
the day you're ready to
go to work on a fix.**

TAKE yourself by the hand and come out of that corner, Frizbi! Just because when you needed more cleaning compound for the steam cleaner—and spare parts weren't able to pass it over the counter to you right then and there, is no reason to raise a rash and start calling in all the local salesmen.

Buying this stuff local purchase may or may not be good business—because the stuff you get may, or *may not*, be good cleaner. To play it safe and be sure you're not going to plug up your equipment, use only the national brand—advertised by the army as "Compound Vapour Cleaning D.N.D. No. 90822 in the handy 400 lb. drum."

Army issue cleaner can be procured through spare parts. The Army has lots—you can take our word for it. But your local spare parts depot may not have it ready and waiting for you. The idea is to anticipate your future requirements and give your spare parts depot about a month's notice. In that way you're not liable to be caught short. And

that, as you probably know, can be mighty embarrassing if you've got a rush cleaning job to do.

While you're at it, you might well indent for coil cleaner too, because the coil in your "Kerrick" or "Jenny" should be cleaned out at least once a month. This coil cleaner carries D.N.D. No. 90823 and is called "Compound Cleaning, Coil." It comes in one gallon containers.

This "looking into the future" idea doesn't only apply to steam cleaning compound. Even if there was space enough in the local spare parts depot to carry a complete stock of all your future requirements (which there isn't) it would come under the heading of hoarding. In some parts of the country there would be shortages. That's why there's a Central Ordnance Depot. So instead of waiting till the last minute to indent for certain items such as grinding wheels, wire brushes, Sunnen stones or anything else that you know you must have and you know takes a few weeks to arrive—put your order in ahead of time.

That goes for unusually large amounts of paint, floor cleaner or other items you're likely to require in the near future. A little co-operation with spare parts goes a long way in keeping everybody hep, happy and supplied.

x y z

THE OLD OIL

WHEN McPintle snatched up his F type telephone from its cradle, talked persuasively to Mabel for 30 minutes, then noticed that the cradle switch plunger had stuck down, he was unhappy. McPintle knew that, with the plunger in the down position, the battery isn't connected and therefore he had been beating his gums into a dead mouth-piece. Mabel had missed his best line yet.

Which, of course, was no excuse for McPintle's next move.

Laying hands on a handy oil can, he squirted oil onto the plunger—before the nearest Tels man could say nay. He was still unhappy because although the plunger was working better than ever now that it had some oil, why was the Tels man stamping his feet and pouting at him?

Time did tell. Soon the cradle switch plunger would not work at all—unless struck with a sledge hammer. Unhappy McPintle wondered why. He wasn't to know that the plunger rides in a hard rubber bushing. That oil getting onto this bushing will cause it to swell, thereby seizing the plunger. That the correct thing to do, when the plunger gets tight, is to remove it and clean it thoroughly with crocus cloth. But *never* oil it.

McPintle is still unhappy, for when he did find out about all this and finally called Mabel—a man answered.

For B.F.s

DASH BORED

IT used to be said that a lot of automobiles were sold on the strength of a fancy dash panel.

There's also a school of thought which claims that a lot more vehicles could be saved from premature ruin by that same instrument panel.

Playing hookey from this school is the B.F. with a wide eye for fancy trimmings and a blind eye for the instruments.

One of the first lessons the Sergeant taught him was to keep his eyes on the road—and he took the Sarge at his word. Thus, the instrument panel, not falling into that rigid line of vision gets as much attention as a debutante who doesn't use Ponds.

But if the B.F. stops to think about it—(we're joking of course)—the manufacturer must have had some reason for putting in all those fancy little dials and gauges. Give up? Well, trusting souls that they are, the whole idea was to tip you off on impending trouble before it became serious; to keep

you informed, as you bowl merrily along, of the proper functioning of the hundred and one hard working bits and pieces that keep you rolling.

To save you stopping at a garage every five minutes to see if the generator is generating, the cooling system cooling, the oil pump pumping and so on—they put all the information right under your nose on a simple plain panel. The instrument panel, they said, would be the corner stone of the whole preventive maintenance structure.

Which sounds fine—what are we worrying about?

Just this. They forgot about B.F.s. They left it up to our friend to keep an eye on all the needles and gauges. What's more, they left it up to him to recognize the symptoms of up and coming trouble before something drastic happened.

That, if we may say so and I guess we have . . . *that*, is where they tripped over their slide rules,



*. . . a wide eye
for fancy trimmings . . .*

for a dyed-in-the-wool B.F. never looks for trouble—he waits for it to catch up with him. Which it usually does.

To illustrate: an extra high reading on the heat indicator doesn't mean summer's here. Rather it's a warning that something cooks. It may be caused by any number of things from a shortage of the right liquids in the rad or crankcase to wrongly adjusted carburetion or ignition.

If a tachometer is there, it can point the finger to an engine, clutch or propeller shaft that's being knocked dizzy by over-speeding—regardless of road-speed.

An oil pressure gauge keeps tab on whether or not an engine is getting its lubrication—full crankcase or not.

Instruments of all kinds—like watch dogs with their snouts tilted for a possible ill wind.

You get the idea. But our guess is—until the makers incorporate sirens, bells, and whistles, with a boxing glove that shoots a straight left to the ear when the instruments have something to tell, B.F.s will continue to drive a vehicle by the seat of their pants. That is, unless they suddenly realize that a hitch caught in time saves nine times the repair effort needed later in a workshop.



. . . when the instruments have something to tell . . .

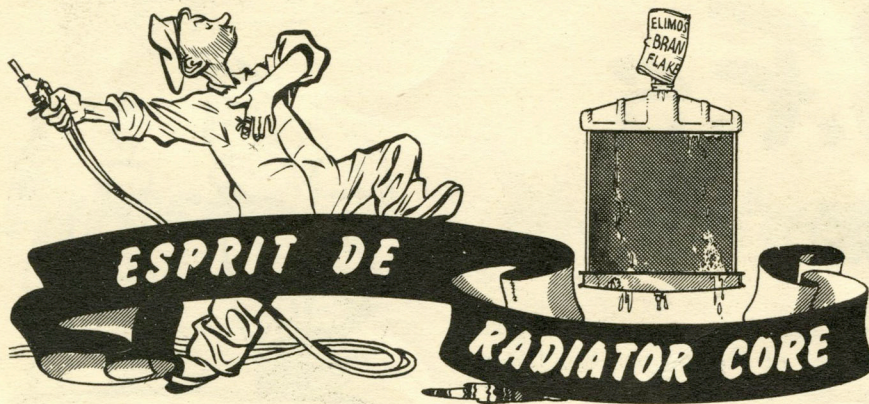

DURING the past few months we've been getting memos in our mailbags telling us that CAM's pages have been void of radiator repair information. Now, we know that it's not everybody's business to repair rads, but it's quite plain that the boys who do repair them like to swap yarns and ideas. That's why we gathered a hatfull of tricks from here—there and everywhere. Some of the info came from the West, some from the East and some from Cpl. In-between. We dumped it all in our smudge pot and after a certain amount of mixing, boiling down and straining we've cooked up something for everybody who's interested in radiator fixes.

One thing, you wanta know

Stoppin' up a leaky rad with bran flakes and condensed milk ain't the spirit of enthusiasm and co-operation we mean.

before you get a rad off the vehicle and go to work on it—is it worth repairing? If, when you cast your pretty blue censorious eye over the core, you see white powder deposits, you can suspect a rotten core. These white deposits are lime or magnesia and mean that a certain amount of seepage has been going on behind your grill. If seepage has been occurring over a large

area there's not much point in trying to repair the old core—its cooling days are over. Visual inspection should also take in other things — such as visable leaks, damaged fins, etc. But suppose the rad is worth repairing?

The first thing to do is clean it—outside and in, everybody agrees to that. The methods of cleaning differ slightly however, depending on the equipment available. Some of the boys, who've been in the business since they were weaned, have built up elaborate testing and cleaning equipment but the methods we're going to dish out are the simple ones, enabling complete and effective repairs with the minimum of equipment.

The most common method of cleaning the mud, the dirt, the butts and the etcetra off the outside is to give it a good hosing with the Kerrick Cleaner or Steam Jenny. This outside muck will come off when you boil out the insides but if you take it off first you won't muck up your cleaning tank as fast.

Proper cleaning of the inside is one of the main objects in a radiator repair man's life. The purpose of the core is to dissipate heat from the water through the fins to the air stream. To do this efficiently the water in the cooling system must contact the inside surface of core. During normal operation of the engine an insulating blanket is bound to form. This thin coating, caused from impurities in the water, oil, grease, dirt and rust, must be removed.

Cleaning tanks can be of various sizes—just large enough to hold one rad, or large enough to hold several at one time. The most popular method in the army is to mix about fifteen pounds of Kerrick Cleaner compound to thirty gallons of water and completely submerge the core in this solution. Then boil for about three hours. The solution should be strong

REVERSE FLUSHING TOOL

Fig. 1

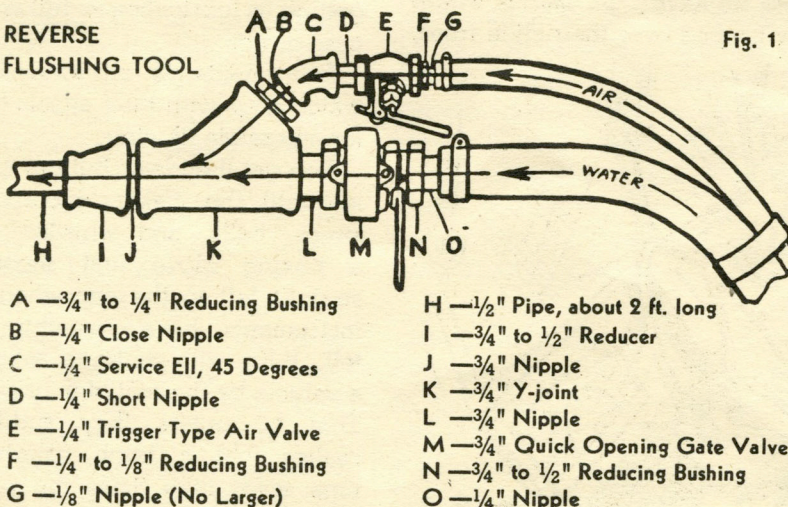

- A — $\frac{3}{4}$ " to $\frac{1}{4}$ " Reducing Bushing
- B — $\frac{1}{4}$ " Close Nipple
- C — $\frac{1}{4}$ " Service Ell, 45 Degrees
- D — $\frac{1}{4}$ " Short Nipple
- E — $\frac{1}{4}$ " Trigger Type Air Valve
- F — $\frac{1}{4}$ " to $\frac{1}{8}$ " Reducing Bushing
- G — $\frac{1}{8}$ " Nipple (No Larger)

- H — $\frac{1}{2}$ " Pipe, about 2 ft. long
- I — $\frac{3}{4}$ " to $\frac{1}{2}$ " Reducer
- J — $\frac{3}{4}$ " Nipple
- K — $\frac{3}{4}$ " Y-joint
- L — $\frac{3}{4}$ " Nipple
- M — $\frac{3}{4}$ " Quick Opening Gate Valve
- N — $\frac{3}{4}$ " to $\frac{1}{2}$ " Reducing Bushing
- O — $\frac{1}{4}$ " Nipple

enough to remove paint off the outside of the rad—if it isn't, add more soap. If the tank can be heated by a gas burner so much the better but if there's no burner available, the Kerrick or Jenny steam cleaner can be used. By placing the nozzle of the steam cleaner in the cleaning tank so the tip of it is on the bottom, you can run live steam through the solution in the tank. Two to three hours of this treatment should leave the core cleaner than the hard luck guy in a crap game. Then it should always be flushed out and tested—just to make sure.

When the core is taken out of the cleaning tank it will most likely be filled with loose rust and scale. This can be flushed out with clean water and air pressure. A satisfactory flushing gun can quite easily be made up of odds and ends. The particulars of the one shown in Fig. 1 are contained in "B" Vehicle Service Information Bulletin L-3 or in C.A.L.E. M.E.I. Veh. Gen. B-107 Inst. 1, which should reach the field soon. If you're fresh out of odds and ends authority will be granted to buy a gun on local purchase, if an indent is submitted in the regular manner.

The best method of flushing is to screw the radiator filler cap in position, (sometimes it may be necessary to put a rubber washer under the cap in order to get a good seal) and connect a lead-away hose to the upper hose connection. Then connect the flushing gun to the lower hose connection and flush till the water runs out clear. Go easy on the air pressure though because the core is pretty fragile and won't stand high pressure or sudden blasts. On Ford rads—leave the two top connections open, plug one of the lower connections and connect the flushing gun to the other lower connection.

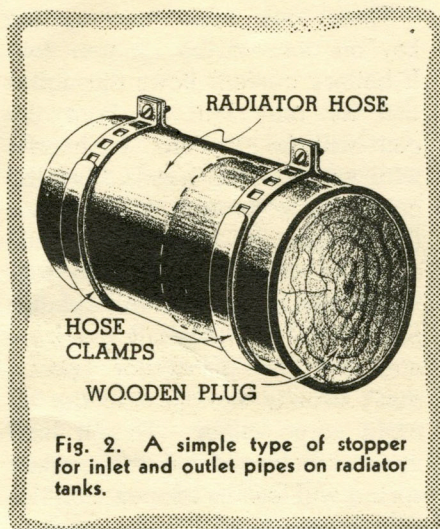

We've seen several ideas for these plugs. One type that's simple to make only requires a short piece of radiator hose, two hose clamps and a round wooden stopper to fit the hose. When it's completed it looks like the one shown in Fig. 2. A set of plugs of different sizes should be part of your radiator repair equipment. Now you're ready to see if you did a good cleaning job.

One of the quickest and easiest tests we know is to fill the rad with clean water—at the same time holding the palm of your hand over the bottom connection. When it's full—take your hand away quickly—the water should gush or squirt out of the lower connection for a distance of about 10 or 12 inches. If it doesn't, back to the cleaning tank she goes for another couple of hours. To test the squirting power of split rads like Ford, you'll need to plug one of the lower connections.

When the core comes out of the cleaning tank and is flushed for the second time it should be virgin clean—only more so—but to make sure give it another test, then if it's O.K. you are ready to test it for leaks.

If for some dirty reason, part of the core is still plugged, you'll have to clean it the hard way—

the pipe cleaner method. Remove the upper tank by unsoldering the seams then rod out the plugged passages. On tubular type cores this can be done with a round wire with its end rounded to avoid puncturing the tube. On honey-comb type cores use a flat strip of metal with its edges and end rounded and not quite as wide as the water passages.

One point all radiator men agree on—there are always at least as many leaks as you can see. So, any leaks that are visible should be looked after first—then the test will show up the remaining ones.

There are two methods of leak testing—the air test and the water test. The air test is the better of the two but many use the water test due to the less amount of equipment required.

To make the air test the filler cap should be screwed on tight—you don't want air to escape here. Also the inlet and outlet connections must be plugged and an air line connected to the overflow pipe. With the entire rad emersed in a testing tank of clear water, air must be forced into the core through the overflow pipe. Air bubbles will appear wherever the leaks are. A hand operated tire pump or an air compressor can be used to supply the air pressure, but never use more than *five pounds* pressure because a higher pressure may cause damage to the fragile core. Therefore, if you use this method of testing, you should have a pressure gauge in your air line. The spots where bubbles appear can be marked by various methods. Some use tapered wooden plugs and some clip a cotter pin to the fin next to the leak. One resourceful man-about-town we know uses bobby pins which he collects on the back seat of his car. Sometimes air bubbles will appear from a leak on the opposite side of the core—for this

(Continued on page 160)

Switch off at Bedtime

WITH a hundred and two things (like Mabel, wet canteen, Mabel, chow, Mabel etc.) on your mind when you pull into camp after a long dusty day, it's possible for a guy to run into a set of circumstances whereby his ignition key gets left "on" all night. In the quick scramble of a C.P.M.S. 3, these things can happen.

Trouble is, a guy's got to meet his three hooked Nemesis next morning and mumble something about "somebuddy musta turned it on durin' the night."

As one of the qualifications to be a Sergeant Nemesis is, never believe anything you hear and only half you see—you can expect the worst.

Leaving the key on all night usually results in a battery that's flatter than salt water on a plate. This is bad anytime because when a battery is over discharged it may be ruined. It's particularly bad in freezing weather, when the specific gravity goes down, as the electrolyte can freeze solid and bust the case.

Then look what leaving the key on does to the ignition coil. If battery current flows through a coil for only half an hour the coil will be too hot to handle with your nekkid hands. Let the current flow through it all night—(or as long as the battery lasts) and the coil will blow its top. We're not kidding; it will splatter pitch and windings all over the engine. The distributor points don't usually stand up to the all night spree either. They'll heat up and before dawn the contact spring will lose its temper.

So to save time, trouble, expense and consequence—remember to see that the ignition is turned off when you leave your vehicle. If your mind is on something else, tie a string on your finger and tie the other end of the string to the ignition key.

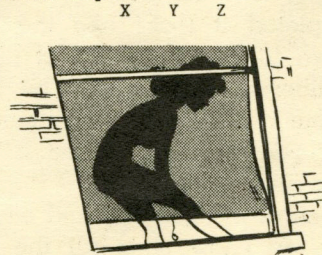

Last Post for Motorcycle Batteries

YOWSA—it'll be a big amen if someone doesn't holler loud and long about the number of motorcycle battery posts being broken.

Seems like every battery shop we go into, there's a pile of these batteries with broken posts, ringed about with a little group of battery men, crying in their electrolyte. Seeing us, they usually sob their way over to our solid cedar shoulder pads and pour out their story. (Incidentally ruining our 39¢ pressing job in the process).

"Tell them monkeys" they howl, "to lay offa them pliers, pry bars, pipe wrenches and other such battery post busters when they comes to a m'cycle battery with

corroded terminals. When they're stuck they're stuck."

"Yeh," we say, "but when they've gotta get 'em orf, they gotta get 'em orf."

"Hokay", they come back, "tell 'em to use a hacksaw and cut 'em off—the bolts, not the lead terminals. Bolts is cheap and easy—but watta we gonna do wit a battery post that's chiseled, hacked or busted off to a nub? I'll tell ya—we gotta go to work and remould a new post on. A sweet job!"

Not having a ready reply, we usually take a powder at this point—leaving the battery bloke our solid cedar shoulders to continue his sobbing on.

FORMS FOR SMALL ARMS

... as explained to Dement T. Rowdy (our S. A. Correspondent) by Cpl. Kizel.

I DO not want any of you citizens to get the wrong impression of Canadian Armourers from the uncomplimentary remarks that I occasionally utter about one known as Kizel. My remarks in that direction are purely personal opinions which, in this case, may be due to the fact that I do not like the shape of the guy's face. To show that maybe he isn't so bad I will relate what happens last week when I am up in the Directorate of Mechanical Engineering, N.D.H.Q., visiting Kizel on his new job.

At the same time that I am making free with Kizel's cigarettes, there is present the chief armourer from one of the districts, and he asks Kizel as follows, "Why is it that we are all the time making out Inspection Report Forms for you people and what do you do when you get them?"

At this, Kizel, without saying a word, takes this character by the hand and leads him along to a row of filing cabinets and says, "These are the Inspection Reports that come in here from all over the country. They are checked by our staff to find what repairs are the most popular in Canada and this information is used as a basis for the adoption of preventative measures and as a guide to what modifications are required on all the various equipments."



"For instance," he goes on, "if many of the rifles across the country should be reported to have split wood, a C.A.L.E.M.E.I. would have to be written telling the proper way to prevent such unfortunate happenings. That is the way," he continues, "we keep track of necessary repairs; the way we would like to look after defects I will explain shortly. From these reports we can also deduce the quantity of each type of spare part that will be required for upkeep of small arms and will not unexpectedly run out of the more widely used components."

"Now besides checking these points," Cpl. A. B. Kizel says, "We also look to find out the state of unit maintenance and if we find it is not up to scratch we can rap somebody on the knuckles. This is inclined to encourage healthy maintenance."

The visiting brain looks the filing system over, noting the odd check marks on the pages of the completed reports and the way they are filed by date, unit, district, etc. etc. etc., and wanders back to Kizel's desk muttering about people always checking up on him. After he has had time for his brain to absorb all he has seen and heard, he speaks as follows. "Well now I am satisfied that my valuable time is not wasted every three months making out these forms, but what is this other business you hinted at awhile back?"

"Yes," says Kizel, "I gotta

peeve. Continually we hear deep dark rumours that some particular detail of Small Arms equipment does not meet with the thorough approval of the man in the field. But we can't go to the manufacturer and say 'it is rumoured about that such and such is wrong.' Only if the various characters in the field who are not happy will send us a copy of M.F.M. 211 (Design Defect Field Report) properly filled out, explaining their beef we will be able to wave same under the nose of the manufacturer and get action."

The visiting brain plants his left foot in Kizel's mouth and during the ensuing silence asks, "Where do I find out how to make out this M.F.M. 211?"

Kizel smiles broadly and fumbles through his wastepaper basket to find C.A.L.E.M.E.I., General H 206 (C.A.), saying as he does so, "This will tell you how to do the submitting of the form, now it is up to you to keep us in the picture by doing so. After all, the Directorate of Mechanical Engineering is here to help solve the problems of the guy in the field, but if the guy keeps his troubles secret, we are just as likely as not to think that everything is O.K."

"As an example of what is happening up to this time," says Cpl. Kizel, warming up again, "take the business of bulged No. 4 rifle barrels. Only one M.F.M. 211 was received by the directorate reporting replacement barrels, factory new, with bulges near the muzzle. The masterminds on the

engineering staff thought that this was just an isolated case, until months later vague rumours found their way back to us concerning the self-same defect. In our usual direct manner we immediately put aside our Dick Tracy comic books and canvassed every district by wire to see what basis the rumour had. All but one district reported the same trouble and with this to work on we soon had things under control. Now if every district had put in an M.F.M. 211 on the spot we would not have had to drag the story out of the field bit by bit with telegrams."

Kizel then turns his big blue eyes innocently in the direction of the sky and quotes, "Of course since you are a big shot district armourer there is no need for me to explain to you all the forms you deal with such as M.F.C. 777, M.F.M. 199, N.D.F.C. 637, M.F.C. 607A, Workshop reports, M.F.M. 198, M.F.C. 628, N.D.F.C. 573, N.D.F. 7, M.F.M. 205, M.F.M. 204, M.F.M. 202, M.F.M. 203, and M.F.C. 619, because you will natchaly know what they are."

Just in case some character will ask *me* what all those forms are, I sneak out quick and find out. If *you* don't know, you might gander over this list and find out too—just for the hell of it.

You know, maybe this Kizel guy isn't as dumb as I give him credit for all these years.

X Y Z

- M.F.C. 777 —Record of Annual Inspection of Arms by District Armourer
- M.F.M. 199 —Receivers Memo
- N.D.F.C. 637—Repair Indent
- M.F.C. 607A—Ordnance Transfer and Expense Voucher
- M.F.M. 198 —Issue Voucher
- M.F.C. 628 —Inventory of Furniture, Utensils, etc.
- N.D.F.C. 573—Indent for stores
- N.D.F. 7 —D.N.D. Packing Note
- M.F.M. 205 —Ordnance Workshop Order—Spare Parts Issue Vouchers
- M.F.M. 204 —Report of Ordnance Inspection (Army)
- M.F.M. 203 —Inspection Stocktaking Sheet
- M.F.M. 202 —Preliminary Stock-listing Sheet
- M.F.C. 619 —Armourers Report (Used where charges are to be made only)

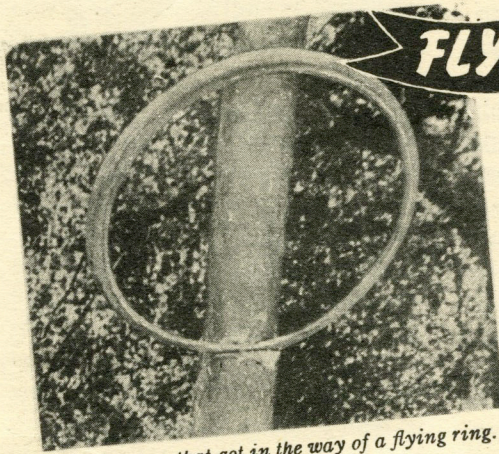

Here's a tree that got in the way of a flying ring.

FLYING LOCKING RINGS

Keep them in the groove
and keep your head

YOU'VE seen locking rings and don't need us to tell you they hold the tire in place on the rim. These rings, while they don't actually make mounting and demounting tires a pleasure, at least make the job easier. You'll find them on all flat base and semi drop centre rims. How they go about the job of holding the tire bead in position is shown in Fig. 1. The rim gutter which holds the locking ring in place is deep enough and strong enough to hold the ring in place, provided the ring is properly seated all the way around. When the ring becomes twisted, sprung, out-of-shape — or won't seat properly due to dirt, rust or scale in the gutter — watch out. They have to be the correct locking rings too, if they are to seat properly. Even though the difference between

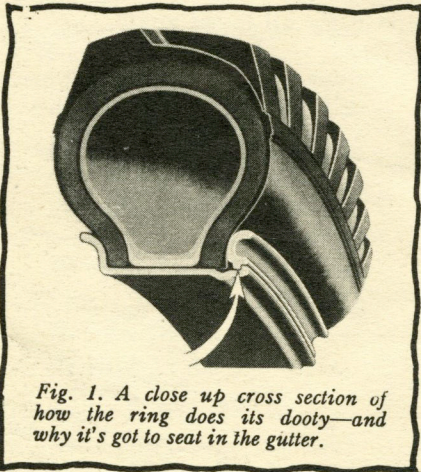

Fig. 1. A close up cross section of how the ring does its dooty—and why it's got to seat in the gutter.

locking rings of various makes may be slight, as far as we know at the moment it's not safe to interchange them. If any can be interchanged with safety, we'll slip you the dope in next month's CAM.

But maybe you are wondering why these babies can be so dangerous. That's why we got Digit, (the guy who keeps our figures in shape) to tell us how much pressure is behind a tire locking ring, when the tire is inflated to normal pressure. Know what he said? 106,480 pounds on a 750/20 tire when the tire is inflated to 55 pounds. That many pounds pressure will cause the locking ring to pack a wallop like a land mine if it slips out of place when the tire is being inflated or while the ring is being pounded in position after it is inflated.

If we were directing this story to Tojo and his mob we'd suggest and hope that when they installed a locking ring they *wouldn't* examine it closely to make certain it was the right type. We'd also suggest that they leave the rust and dirt on it so it could slip out easily. Then when they inflated the tire we'd tell them to find a spot crowded with Nips — point the locking ring side of the tire into the mob and inflate it quickly. They might as well stand in front of it too—with their neck well out. All this would save our boys a lot of time and trouble.

But for safety's sake — don't you do it that way. Take every precaution possible to make sure the locking ring is seated in the gutter *before* you inflate the tire. Then, as an added precaution, assume that the ring may spring out. Stand clear so it will miss you and point the tire so the ring won't do damage to people or things if it does let go.

Even facing the locking ring side of the rim to a brick wall or building can be dangerous. If the ring springs out it might hit the wall then bounce back and knock your block off. Sitting on the wheel while inflating it is not good either.

One of the safest methods we have heard of is to insert a tire iron or crow bar through the wheel as shown in Fig. 2, then inflate the tire to about ten pounds pressure and tap the lock ring lightly to make sure it is properly seated. Then you're all set to fill 'er up to the required pressure. If this method is not possible, the next best way is to inflate the tire to about six to ten pounds pressure, check the seating of the ring by lightly tapping it and then turn the wheel over so that the locking ring side faces the ground before you attempt to inflate the tire to its final pressure. This method is reasonably safe — but like we have said several times — always expect the worst from tire locking rings and you'll have a better chance of staying in one piece.

X Y Z

Fig. 2. The simplest and safest way to hold that deadly ring in place if the wheel has ventilating holes.

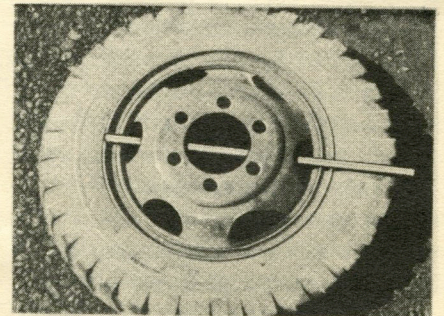

THE Cam-Pains OF... BENNY BOOB

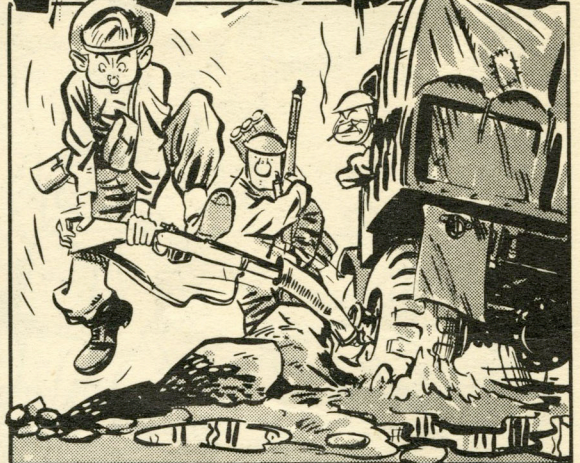



Valve Springs

Dear O'Sweat:

Maybe I was just born inquisitive because I've got a silly little question to ask you. Nearly all valve springs are made so that the coils are bound tighter on one end of the spring than the other. The manuals tell you to install them with the close coils nearest to the block on side valve engines and nearest to the head on overhead valve engines, but they don't say why.

I'd be much obliged if you can throw some light on the subject.

Cpl. E. E. M.

Dear Cpl. E. E. M.:

You and your inquisitiveness! Your simple question ain't as simple as a valve spring looks. Howsoever, to get the story down so it'll fit on the head of a valve, here 'tis.

Valve springs have to work at a terrific clip to keep the tappet following the contour of the cam. Because of this, they do funny things. If you've ever watched

one of them under a stroboscope, you'd see it snaking like a hula hula. So one way hit on to try and give such a flexible structure some rigidity was to close the coils up more at one end.

Natchaly, these closed up coils have to be where the least movement occurs (against the block or the head) to get a progressive action in the spring as the coils close up successively — also lessen any tendency for periodic spring vibration (remember the idea of breaking step when crossing a bridge?).

The closed coils make their end of the spring heavier. As we want to keep reciprocating weight to a minimum they've gotta be at the end which has the least movement.

There's a couple dozen more theories having to do with sympathetic vibration, metal fatigue, valve rebound, etc., etc., but I think the story above will get the idea over.

O'Sweat

Jeep Speedometer Trouble

Dear Sgt. O'Sweat:

... You, my dear Sarg, have solved other people's problems, so why not mine?

It's speedometers. Jeep speedometers. The pointers go 'round and 'round until they finally tire of such foolishness and drop off. Some of them grind and whine like a transmission without D.N.D. 390, until the driver in desperation removes the cable. A couple of them quit on the speed recording but continued to show miles travelled with fair accuracy. Others after several days of grinding and spinning gave up the ghost completely and now sit there to stare at me with dead eyes.

This all started in mid-winter during our coldest weather, and the local brains decided it was something to do with condensation inside the head. So that's fine and we take the old one off and put a brand new speedometer on. It works fine for 200 miles, or maybe 500 — then away they go again, spinning, grinding, and quitting.

In our own unit we replaced five speedometers in January, only one of which is now operating properly. Since then two others have gone. I also hear that other units in the area are experiencing the same difficulty. Ford truck speedometers, however, are all working perfectly.

My idea is that seven out of eleven is too big a percentage of failures. There must be something wrong, and I'd like to know if there is anything to do to prevent or correct this condition. Besides, look at the mess it leaves my log books in.

Yours,

Lieut. J. C. K. N.

Dear Lieut. J. C. K. N.:

Your letter started me rooting around to find how much of this same trouble existed in other dis-

tricts. You'd be surprised what I found.

On certain makes of speedometers, the lower bushing has a tendency to wear, letting the main shaft drop down and touch the magnet. This results in a mechanical connection between the magnet and main shaft where there should only be a magnetic connection. If there is too much, or the wrong kind of grease on the cable the grease will work into the head causing similar results — particularly in cold weather. If the speedometer cable is too long it will press against the main driver resulting in shortened bushing life and as before — the magnet and main shaft will make a mechanical connection.

Any one of these things could cause failure of the speedometer and it would most likely act the way you said — whine, break off the aluminum stop on the inside and then spin like a roulette wheel. When your drivers see or hear the first signs of trouble — even a jittery pointer, they better disconnect the cable pronto to avoid any further damage. Then trade the head in for a good one at Spare Parts but make sure the cause of grief is corrected before installing the new head.

There's a lot more to say — how spare parts men can go wrong in making up a cable — and how the cable should be installed. I haven't room here so I batted something out on page 156. How about spreading the info among them what needs it?

Now see all the work you put me to!

O'Sweat

Battery Polarity

Dear Sgt. O'Sweat:

Probably you've been asked this question before — I know I have many times. So far though I

haven't seen an explanation in CAM or any place else.

Here is the question and I hope you can give me an answer that I can pass along the next time I'm asked. Why do some vehicles have positive grounded systems while others have negative grounded systems?

Sgt. F. L. D.

Dear Sgt. F. L. D.:

As you know, time has changed many theories on electricity. For years it was believed that electricity flowed from positive to negative and that vehicle electrical

O'S LOVES S.W.P.*
*Soldiers With Problems

..... specially maintenance problems!
Has a manual got you muddled?
Is a bulletin buffalooing you?
Are you irked by a quirk in your work? If where you are, the answers ain't—pass your poser to O'Sweat. If there's an answer, he'll get it for you. Better still, if we can print the question and answer, you get a **PERSONAL SUBSCRIPTION to CAM—you lucky dog.** Write 'Dear O'Sweat' CAM magazine, D.M.E. Department of National Defence, Ottawa.

systems could only work one way — with their negative posts grounded.

Then one day, and up an coming electronic genius confused everybody by saying that no one really know'd which way the current flow'd if it flow'd at all.

Result is, some manufacturers continued to use negative ground and some changed to positive grounded systems. In a nutshell it didn't make much difference because both systems work equally as well as far as operation of the electrical units are concerned. The manufacturers who are using

the positive grounded systems have a couple of good points though. Here is the way they figure it.

Corrosion from acid spray is always worse at the positive battery post. This corrosion, in time, will eat into and damage the battery cable. If the battery is positive ground the corrosion only damages a ground strap — which is less expensive to replace than a long insulated cable to the starter. That's the first point. The second point is that the acid spray will form a damp surface on the top of the battery which allows a trickle of current to leak from the positive post to the battery hold-down clamp and to ground on negative grounded systems. By grounding the positive post there is less chance of this leakage occurring.

Of course I know and you know that the batteries in army vehicles are *always* kept clean so there is never any corrosion or leakage regardless of battery polarity. Ain't it the truth?

O'Sweat

Propeller Shaft Brake Drums

Dear O'Sweat:

Not long ago a G.M. 3 Ton 4 x 4 came into the shop with instructions to stop the vibration which was noticed when the truck was driven over 20 miles an hour. We checked everything we could think of that might be causing the vibration such as the drive shaft, universal joint, etc., but were unable to find the cause. In the end we gave it up as a bad job, figuring it was a lemon.

Yesterday another 60 cwt. came in with the same complaint. Something in the drive shaft assembly causes a terrific vibration at any speed above 20 miles an hour. Have you ever heard of this?

Cpl. S. S.

Dear Cpl. S. S.:

I took your letter to bed with me along with a flock of factory bulle-

SPEEDOMETERS are NECESSARY!

Don't let the thing ride—
without having it work.

ANY vehicle will run without a speedometer — the question is, how long will it run? With no odometer to record the miles and no speedometer to indicate the speed, you are blitzed, befuddled and bewildered. You don't know how slow, or fast, you are going and what's worse—your preventive maintenance becomes a sometime thing. The whole P.M. system is based upon mileage. Not knowing when your vehicle has ticked over the 1000 or the 5000 mile mark means you don't know when the C.P.M.S. 4 or 5 is due. Hiballing along at what you think is thirty miles per can be most embarrassing if some long arm pulls you over to the side and informs you that you were doing 50.

The responsibility for correctly operating speedometers rests on the shoulders of ✓ the spare parts man, ✓ the mechanics, ✓ the driver.

Going in reverse — let's see what the driver has to do with it. His job is easy. All he does is read it and if he notices anything screwy, he acts quickly. For example—if the speedometer hand develops the jitters — if the pointer sticks, or if the damthing starts to whine—the driver disconnects the cable from the rear of the meter. By doing this he may save the guy who has to repair the meter a heap of trouble and time. Just like if the engine started to knock—he wouldn't keep on running it till a piston poked its ugly head

through the hood. Next, it's the driver's job to keep track (as close as possible) of how far the vehicle travels without the odometer operating, so he can keep his log book reasonably straight. Being on the bit, he also reports the trouble so it can be repaired or a new meter installed as soon as possible.

The mechanic's job is simple too but very important. Not that he goes poking around inside the meter (regardless of how fascinating it may be). Repairing a speedometer head requires special tools and equipment. Without these, plus the knowledge of how to repair, magnetize and calibrate them, nothing but harm will come of poking into it. Treat the head like a burned out sealed beam unit—turn it into Spare Parts for a new one.

The mechanic's job is to look after the speedometer cable. He takes it off—cleans it—checks it and lubricates it. Performing these jobs requires a certain amount of

O'SWEAT—

Continued from page 155

tins because I had a faint recollection of seeing something about this before. Now I'm sure of it.

It wasn't long before I ran across a G.M. bulletin which says that a few vehicles got out with unbalanced propeller shaft brake drums.

These unbalanced drums set up a noticeable vibration between 23 and 30 m.p.h. in high gear.

The best way to make certain this is causing your grief is to slip the drum off and test the vehicle without it. If the vibration has disappeared you've found the trouble. Then you can exchange the old

drum for a new one at Spare Parts.

Besides 60 cwt., you may find this vibration on other G.M. trucks such as 15 cwt., 30 cwt. and gun tractors so don't lose anymore sleep over it before you check the drum.

O'Sweat

talent which all mechs have even though some keep it hidden. It's not using this talent that causes most speedometers to fail. For that reason, if a speedometer develops trouble, it's plumb crazy to install a new one without first finding out what made the original one go bad—and the trouble will more than likely be found in the cable.

This is where the spare parts man enters the story. The majority of speedometer cables are made up in the Spare Parts Depots out of bulk stock. Some of the boys who make up these cables may not know just how much the speedometer relies upon the job they do on the cable. Speedometer cables aren't like brake cables — there is no adjustment. Making the cable a fraction of an inch too long or too short leads to trouble. The worst of the two evils, however, is making it too long because this results in the cable pressing against the main driver in the meter head and before long it wears its way right through the rear bearing. This will let the magnet rub against the main shaft and soon the head requires a major overhaul. The important thing to remember when making up a speedometer cable is *never make it longer than it's supposed to be.*

Before cutting the core, a wise

spare parts man carefully checks both the specifications and the dimensions of the old casing assembly. The boys in the shop can help him a lot by supplying all the dope they can scrape up, such as make, model, type and serial number of the vehicle—besides supplying the old cable assembly. All this info is necessary because there have been several changes made in cab design of certain D.N.D. vehicles, and different cabs call for a different length of speedometer cable.

G.M. POWER BRAKE CYLINDERS

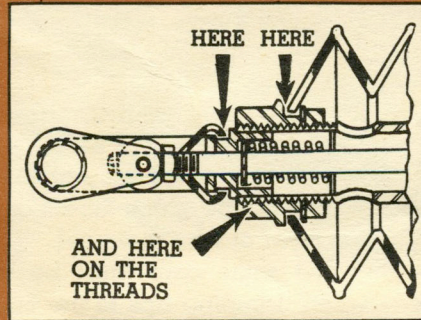

G.M. have come up with a way to keep water out of power brake cylinders. They tell us that during production they are going to seal these units at three places with Permatex No. 2. They also recommend that the jobs already in the field receive this treatment whenever you have them off the vehicle.

The three places where water may enter are shown in the picture. Seal these spots with Permatex No. 2 or a similar substance. Permatex No. 2 is a black, non-hardening gasket cement so don't use Permatex No. 1 because it dries hard and may cause you to frown a little sometime in the future when you try to take the unit apart.

When you can't depend on the specs, a new core can be made using the length of the old casing as a guide, *not the old core.* The old core is useless as a guide because even if it was the correct length once (and there lies a healthy doubt) an accurate measurement can't be taken if it is broken, twisted or stretched. The old casing can be used though as long as care is used because the core, *including its tips* should measure $15/16''$ longer than the casing. Look at Fig. 1 and you'll see what we mean.

This is where it's easy to slip up. The depth of the holes in the tips must be taken into consideration (if tips are used) and the overall length of the new core should be double checked with the tips in position before they are swedged on. This is just to make sure you will end up with a core that is exactly $15/16''$ longer than the casing.—O.K.?

Something else that causes faulty meter operation is the treatment the bulk cable gets in the stockroom.

Hanging them up by their hubs, (like a roll of T. tissue) instead

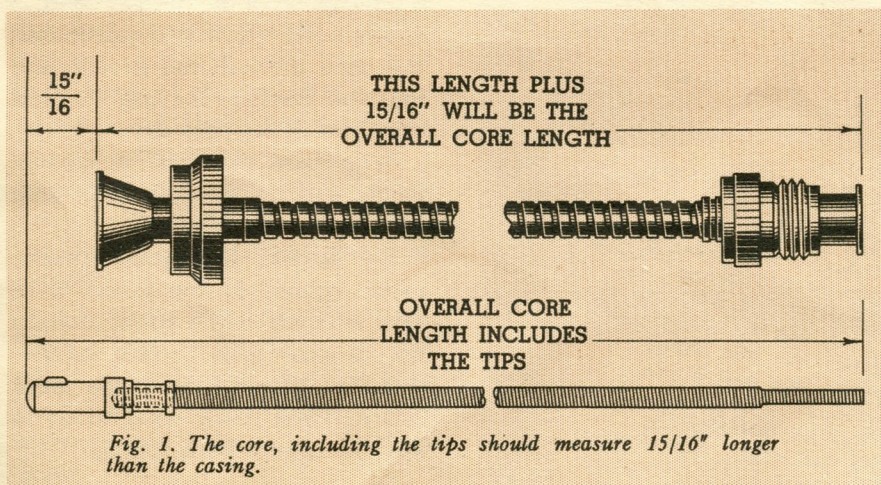

Fig. 1. The core, including the tips should measure $15/16''$ longer than the casing.

of laying them flat on a shelf, is sound business. We don't know how many meters are operating on vehicles with a case of the jitters—just because the cable got a kink while it was lying in the stockroom but it's our guess there's plenty. A pound of prevention costs less than an ounce of cure—so why not hang the cable up? Then tie the free end to something, without kinking it, so it won't dangle to the floor and get stepped on.

Then there's the little matter of forming the square ends on the core. A good cable is one that has its square ends evenly centered (concentric) with the rest of the core (Fig. 2). To form the square end, place the correct amount of core in the fixture. Hold it firmly and in a horizontal position while you give the fixture several smart cracks with a heavy hammer. After each blow rotate the core in the die one-quarter turn and continue till the square

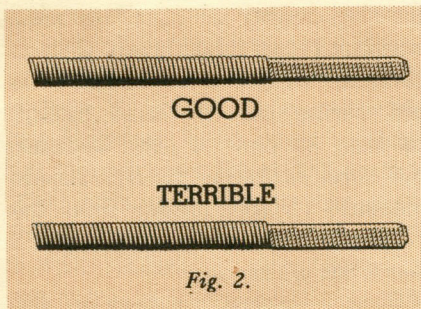

Fig. 2.

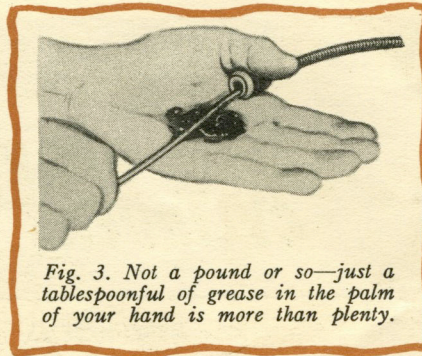

Fig. 3. Not a pound or so—just a tablespoonful of grease in the palm of your hand is more than plenty.

is formed. After that, dress the frayed end on a fine emery wheel by rotating the core against the wheel in the same direction the top layer of wire is wound.

The same care must be taken when crimping tips to the ends of the core. The tips must be crimped on firmly, they must be concentric to the core and they must be the *right tip for the job*.

If the old cable casing is kinked, stretched or damaged in any way, or if its end fittings are damaged it must be replaced. When crimping on the end fittings don't underestimate the weight of the hammer and overestimate the strength of the casing. Be oh so gentle. If you don't, the casing will collapse on the core—and cursed be the core that binds.

A little trick some of the boys use in the parts depots is to insert a short piece of welding rod in the casing while they crimp on the end fittings. This prevents the

casing from collapsing. The welding rod must be a snug fit inside the casing.

To save himself unnecessary work, a good mechanic will check both core and casing for kinks before installing it in the vehicle. Give the core the "roll test" by laying it on the flat surface and rolling it with your fingers. If a "kink" or "whip" is seen or felt and isn't too bad it can sometimes be removed by tapping *lightly* with a hammer on the 'up' side of the whip.

The most frequent cause of trouble is improper lubrication of the cable. *Use grease sparingly and always use the proper grease*. If too much or the wrong type of lubricant is used it will creep up the cable into the speedometer head and properly gum up the works.

The right lubricant to use is D.N.D. 681. This is not what you have been using in the past but about the time you read this, a brand new CALEMEI will hit the field giving you the official word of this new lubricant to use.

Only lubricate the lower two-thirds of the core. After first washing and cleaning out the inside of the casing, (a pull-through is a good way of cleaning it) hold the instrument end of the casing in the left hand. In the palm of the same hand place about a tablespoon of the grease. (Fig. 3 shows how). Now you can thread the core through the grease and into the casing—leaving the last one-third of the core dry.

With care like this, a speedometer will do its stuff for a long time with no back talk.

So, Driver, look your speedometer square in the face. If it says 'nothing' while you're cutting the breeze—if it growls back—if it isn't keeping tab as the miles roll by—you know what to do to start the grease balls rolling.

X Y Z

FROM BENNY BOOB'S NOTEBOOK

Wot are you witlin sez lathe to miller just a gun strap sez miller wots a gun strap sez lathe Y thats the part wot holds the gun to the recoil sistim sez miller Y are you makin a strap they are made with the recoil block they are part of it sez lathe troo sez miller but some dup sens in a recoil block for overhaul and forgets to inklude the gun strap with it so I have to swet out a new one O sez lathe dont he no about calemei armt A055 CA instruction number 2 witch sez assemblies transferred between ordnance and units and must be shipped complete with all parts and fittings to witch sez miller I gess he dont.

THE OLD 1-2-3 ON FIRE EXTINGUISHING



Having covered the rudimentary upkeep of your fire extinguisher last month — and now deliriously happy in the thought that every extinguisher in the country is in fire fighting shape—all we want to know is, what to do with it in case of fire.

BEFORE you can pump a Pyrene or trigger a CO₂ with any air of nonchalant skill, you'll want to know what 'Fire' is and what sort of fires you can have.

An old crony of our'n — 'Firebugs Bunny'—put it this way. To have a fire you've got to have three things: *Fuel, High Temperature, Oxygen.* Take away any one of these elements and you can't have fire. So, all a good fire extinguisher has to do to put the fire out is remove any one of these elements.

It may sound silly to say remove the fuel, or the material that's burning, but you may find it a good way of putting out a fire someday. A pump may be throwing a flaming gas or liquid from a broken connection — so first thing you do is shut off the pump. You've simply removed the fuel material.

Lowering the Temperature? Sure. Pour water on a burning piece of wood and the fire goes out. You've lowered the material's temperature below the ignition point.

Removing the oxygen? Well, you've heard of rolling a person whose clothes are on fire in a blanket or rug — the fire is put out by smothering. Maybe you don't always have a blanket or the family broadloom handy, so you use a blanket of gas from a Carbon Tet, Carbon Dioxide or Methyl Bromide Extinguisher. You remove the fire's supply of oxygen. With the chemical extinguisher you've got on your vehicle you're

set to put out most any kind of fire — especially the tough flammable liquid types. These are the babies you *wouldn't* use a soda acid or water extinguisher on.

Water is a good fire-fighter on wood, paper or bales of cotton f'rinstance but more likely to spread a liquid fire — or if used on electrical fires, act as a conductor and hand you a first class jolt of high voltage.

It's best, when using a chemical extinguisher to stand with your back to the wind — especially the Carbon Tet job, as its fumes are capable of slipping you a Mickey Finn. In fact, high temperatures

CAUSE

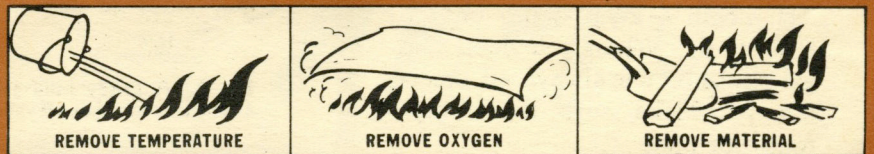

CURE

EXTINGUISHERS Continued from page 159

combined with the reaction of metals and other substances cause Carbon Tet to give off very poisonous gases.

Fumes from the Methyl Bromide extinguisher are less toxic, so use it, if it's available, in poorly ventilated places (like inside an armoured vehicle).

Hard to get at fires are usually best beaten with the rapidly expanding and penetrating gas of the CO₂ extinguisher. While CO₂ is not a poisonous gas — like harmless water, it doesn't provide any oxygen for breathing. So stay clear of concentrations of it. It choked out the fire — don't let it choke you too.

Squirt the spray from Carbon Tet extinguishers at the hottest part of the flame in order to produce the gas that does the smothering. A good trick for ground fires, is to put your finger partly over the nozzle to force the solid stream to fan out like a spray.

Point the CO₂ extinguisher at the base of the flame, or if the fire is over a level stretch of ground, at the part of the flame nearest to you. Shoot in short bursts so you won't discharge the cylinder completely before the fire's out.

The Methyl Bromide is a total discharge type — so once you strike the plunger, shoot the jet at the base of the flames — keeping to windward if possible. If you can bounce the liquid off something solid so much the better as this will cause a spray over the fire.

After the fire's out, don't forget to replace the extinguisher or have it recharged. Then like we said last month — keep going on the P.M. of it. When you need that extinguisher it's always an emergency. Make sure it's always ready for one.

X Y Z

RADIATOR Continued from page 149

reason both sides of the core must be checked.

If you locate the leaks with water instead of air, fill the core with water and dry off the outside. Then, wherever seepage appears, there the leak or leaks will be and there are the spots where you'll mark to be soldered.

Stopping up the leaks is the trickiest part of the whole job but it's no trick at all if you go about it in the right way. Tanks and seams should be soldered with a four pound iron but soldering the core can best be done with a torch. Indenting in the regular manner will get you a torch if you haven't already got one—or—you can make your own. Fig. 3 shows a handy little gas torch that's easy to make.

In any soldering job the cleaning and tinning of the part to be soldered is one of the most important steps. The metal can be cleaned in some cases with a wire brush or scraped with a sharp pointed tool. In some hard-to-get-at parts of the core you will have to rely on acid to do the cleaning. Heat the spot to be soldered (slightly hotter than the boiling point of water) then squirt or brush on raw muriatic acid. An eye dropper or rubber syringe is

slick for applying the acid. Then the metal should be re-heated to the melting point of the solder and use killed spirits of muriatic acid as a flux. When soldering with a torch never melt the solder with the flame—if you try this you'll only burn and oxidize the solder. Too much heat on the thin metal core will burn a hole in it—so just enough heat to flow the solder. If the parts are properly cleaned and heated the solder will run evenly over the surface and seal the leaks in jig time. Use as little solder as possible because too much will destroy the radiating ability of the fins.

Shortage of tin has made the procurement of proper radiator solder a headache. The easiest to use is 50-50, (50 per cent tin and 50 per cent lead) next best is 45-55 and third best is 38-62. Using the better grade of solder reduces the amount of cleaning necessary. To save yourself a heap of trouble in soldering rad leaks, make sure you get 38-62 or better—don't accept 30-70 body solder which is only 30 per cent tin and 70 per cent lead.

When all the known leaks are repaired give the core another test and if you've got 'em all, spray a thin mixture of lamp black and turpentine over the core and call it a job—no leaks—no plugs and ready for cooling.

X Y Z

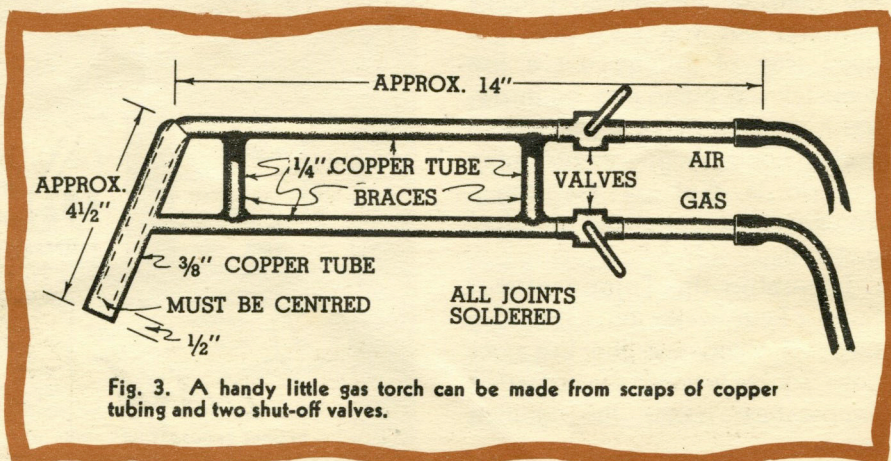

Fig. 3. A handy little gas torch can be made from scraps of copper tubing and two shut-off valves.

So smart'n up m'lads USE 'EM ALL!

WE mean all those tools and instruments the army set us up with to do a smooth maintenance job.

While it's a fact that some of the every day wrenches and such are getting dog-eared to the point of uselessness, there are still the odd few special gimmicks that haven't yet had their paint scratched from legitimate use.

Getting wised up to their time and labour saving uses is just part of every mechs' job—one of the ways he can get to doing better maintenance this week than he did last.

The army wants us to keep our tools and instruments in top shape—replace those worn beyond efficient use—get to know the uses of those special tools—and use 'em all.

Use DEEP SOCKETS on spark plugs. Open end spanners, monkey wrenches or battery pliers will also remove and replace plugs *but* only a deep socket of the correct hex size will do the job without danger to the plug. Cracked and broken spark plug tops only get that way from rough and wrong wrench treatment.

Use VISE JAW CLAMS—copper protectors that will keep the jaws of your vise from gnawin' into the smooth machined surfaces of parts. Teamed with rawhide mallets and brass drifts they're insurance against mutilated work.

Use TORQUE TENSION WRENCHES. Take the guessing out of what's tight—and what's going to come adrift in twenty miles. Smart designers went to the trouble of fixing torque specifications for many important bolts, studs and nuts—clever mechs follow their specs—with a torque wrench.

Use RAGS—the sarges' Sunday shirt will do, so long as there's always a bolt or so of it in your hip pocket. It's the finest tool made for wiping dirt from filler plugs, grease nipples, spark plugs, etc. before opening things up and passing the grit inside to sabotage your equipment.

Use CARBURETOR GAUGES. Float adjustments can't be set with thumb nails or even rulers. Carburetors are sensitive and temperamental creatures; they play hob with performance, valves, plugs and gas consumption when they're not set perfectly—with the correct gauges.

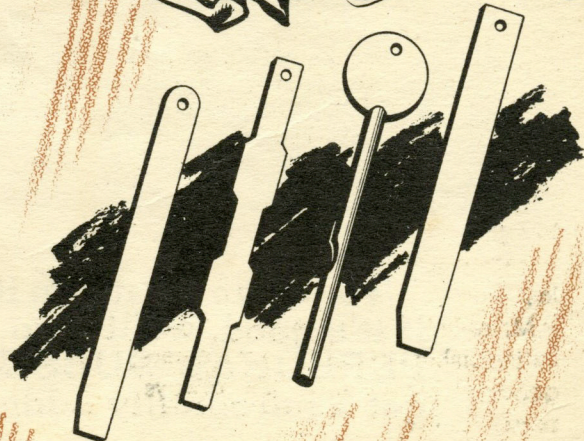
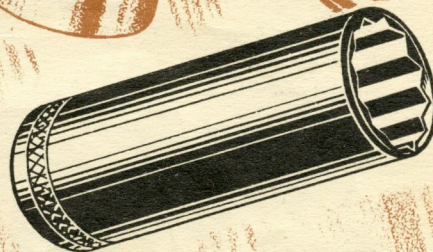

An illustration in a sepia tone showing a man in a military uniform, possibly a sergeant or officer, shouting and gesturing towards a group of soldiers. The man is in the foreground, leaning forward with his mouth wide open. Behind him, several soldiers in similar uniforms are visible, some looking towards him. The background is a textured, mottled brown.

Are you telling us?

SINCE you've been traipsin' all over the country—and perhaps a lot of other countries—you've learned what the sun and terrain does to your equipment.

You've sweated out maintenance service to a flock of trucks, guns and equipage on the salty coasts, or kept 'em rolling at a training centre.

You've learned, sometimes the hard way, the good and bad things in keeping equipment on the go—and in doing so you've had your problems.

But did you ever figure that the maintenance bugs plaguing you are also biting a lot of other guys? That your problems are their problems—and your solutions might be their salvation?

We know it's so and that's why we're asking you to tell us about it. Put down the details and address them to CAM, Directorate of Mechanical Engineering, Dept. of National Defence, Ottawa.

To prove we mean it - we'll not only publish your stuff if it's good, we'll also engrave your name on our yearly PERSONAL SUBSCRIPTION list. That means you get a personally addressed copy by direct mail.